

PRODUCT DATASHEET

QV75-12150MTE

Quiet-Vent 75mm Adjustable Top Entry Distribution Box - 150mm Spigot



Technical Specification

Manufacturer	Quiet-Vent
Part Number	QV75-12150MTE
Type	Manifold / Distribution Box
Spigot Size	150mm
Connection	12 x 75mm
Material	Galvanised Steel
Application	Supply / Extract

Product Overview

The Quiet-Vent 75mm 12 Point Adjustable Top Entry Distribution Box is designed to provide efficient airflow distribution from a 150mm spigot connection to up to 12 individual 75mm radial duct runs. Suitable for use within MVHR and mechanical ventilation systems, it supports balanced airflow across larger residential ventilation layouts where multiple duct connections are required.

Its adjustable top entry design offers added flexibility during installation, making it suitable for ceiling or floor mounting where duct routing may vary. Supplied with 3 blanking caps, unused outlets can be sealed to help maintain system efficiency and airflow control. The unit requires compatible sealing rings to achieve secure, airtight connections, while its L1200mm x W300mm x H90mm dimensions make it ideal for larger installations using Quiet-Vent 75mm radial ducting.

Dimensions

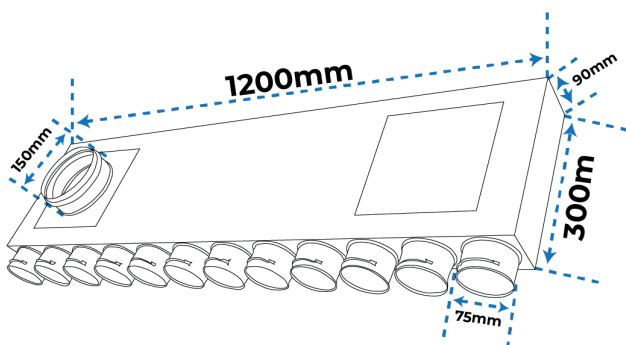

Flow Rate

