

# PRODUCT DATASHEET

## QVCONST90

Quiet-Vent 90mm straight connectors



### Technical Specification

Manufacturer	Quiet-Vent
Part Number	QVCONST90
Type	Connector
Connection	2x 90mm
Material	Polyethylene

### Product Overview

The Quiet-Vent 90mm Straight Connector is designed to provide a secure and efficient connection between two sections of 90mm radial ducting. Suitable for use within MVHR and mechanical ventilation systems, it allows duct runs to be extended or joined in a straight line while helping to maintain consistent airflow throughout the system.

Its simple push-fit design supports quick and easy installation, making it ideal for residential ventilation layouts where reliable duct connections are required. The connector requires 2 compatible 90mm sealing rings to achieve a secure and airtight connection, helping to reduce air leakage and support overall system performance. Built for use with Quiet-Vent 90mm radial ducting, it provides a practical solution for expanding, adapting, or completing ductwork installations.

### Dimensions

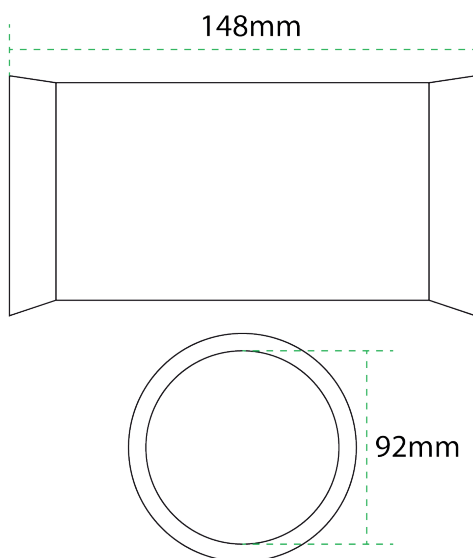

### Related Products



QV90P-HP  
Quiet-Vent 90mm x 50 Metre Antibacterial  
Radial Pipe