

PRODUCT DATASHEET

QVPLEN75AW

125mm TO 2X75mm STRAIGHT CONNECTOR / PLENUM



Technical Specification

Manufacturer	Quiet-Vent
Part Number	QVPLEN75AW
Type	Straight Connector / Duct Adapter
Spigot Size	125mm
Connection	2x 75mm
Material	Polymer
Application	Supply/Extract

Product Overview

The Quiet-Vent 125mm to 2x75mm Straight Connector is a versatile ducting accessory designed to connect two 75mm ducts to a single 125mm duct. Ideal for ceiling or wall installation, this ultra-lightweight connector ensures efficient airflow distribution in both supply and extract valve applications. Its female connectors feature gaskets for airtight sealing, helping maintain system performance and energy efficiency.

Constructed from durable, lightweight materials, the QVPLEN75AW is easy to handle and install, even in constrained spaces. Its flexible mounting options allow installation on a variety of surfaces and planes, making it suitable for complex ducting layouts and seamless integration with other Quiet-Vent components.

Dimensions

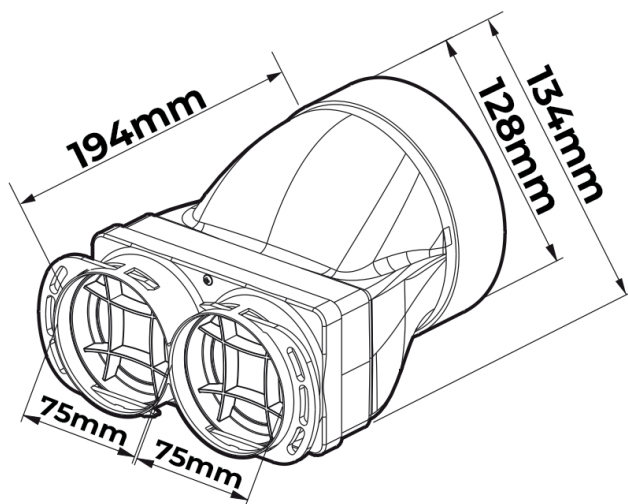

Related Products



QV75P-FS
Quiet-Vent 75mm x 50 Metre Antibacterial Radial Pipe